



MOTORE / ENGINE

Yanmar Diesel 3 TNV 82 31 hp



TRASMISSIONE / TRANSMISSION

Tipo / Type idrostatica / hydrostatic
 Pompa idraulica / Hydraulic pump 2 x portata variabile / 2 x variable displacement
 Portata / Flow 2 x 48 l/min (2x12.6 gpm)
 Motore Idraulico / Hydraulic motors 2 x orbitali 2 velocità / 2 x orbital 2 speed
 Freno di Stazionamento / Parking Brake negativo lamellare / negative disk



IMPIANTO IDRAULICO / HYDRAULIC SYSTEM

Pompa idraulica / Hydraulic pump ad ingranaggi / gear pump
 Portata Std / Std Flow 1 x 33 l/min (1x8.7 gpm)
 Pressione massima / Max pressure 170 bar (2470 psi)
 Distributore / Main valve 3 elementi / 3 way
 Raffreddamento idraulico / Oil Cooler aria / air
 Ribaltamento cassone / Skip tipping system Idraulico / hydraulic



SOTTOCARRO CINGOLATO / TRACKS

Larghezza cingoli / Standard track width 280 mm (9.8 in)
 Rulli inferiori / Track rollers 6
 Regolazione tensione cingoli / Track tensioning si / yes



PRESTAZIONI E DIMENSIONI / PERFORMANCE AND DIMENSIONS

Velocità / Max travel speed 0-7.5 km/h (0-4.7 mph)
 Capacità operativa / Operating load 2000 kg (4405 lb)
 Peso / dry weight 1400 kg (3084 lb) - 1700 kg (3745 lb)¹ - 1900 kg (4185 lb)²
 ROPS si / Yes
 Lunghezza max / Overall length 2800 mm (110.2 in) - 2900mm^{1 2} (114.2 in)
 Larghezza max / Overall width 1260 mm (49.6 in)
 Altezza max / Overall Height 2350 mm (92.5 in)¹

¹ Versione / Type RIX

² Versione / Type ACXW

Equipaggiamento Standard / Standard Equipment

Guida Servoassistita / *Drive with servo assistance*

Ruote e rulli a tenuta permanente heavy duty / *Heavy duty bottom rollers and idler*

Ruote e rulli in acciaio ricavate dal pieno / *Solid steel for rollers and idler*

Martinetti su cuscinetti autoallineanti / *Auto aligning bearing in all hydraulic cylinders*

Pompe a Portata variabile / *Pump with variable displacement*

Cofano motore insonorizzato / *Heavy duty cover engine for noise reduction*

Riduttori con motori a doppia velocità / *Hub reduction with hydraulic motor at double speed travel*

Rulli ad ingrassaggio esterno / *Grease point on rollers*

Presa idraulica supplementare con blocco A/B / *External output*

Manuale uso e manutenzione / *Maintanance book*

Kit attrezzi manutenzione / *Maintance tools*

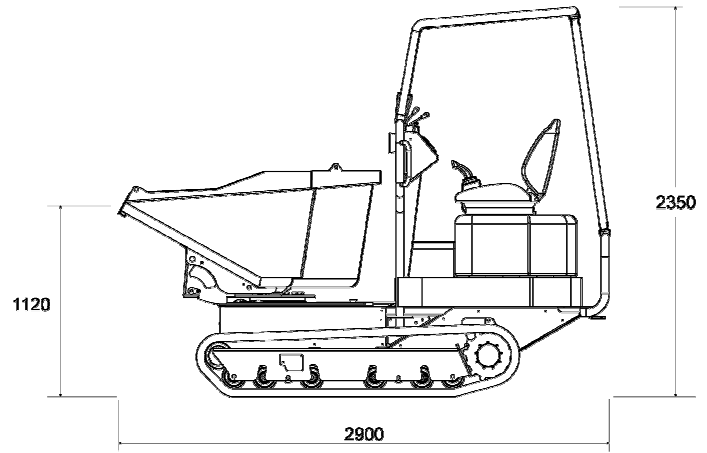
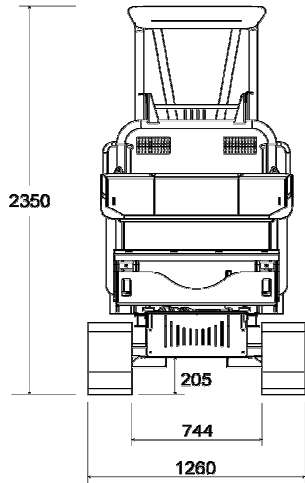
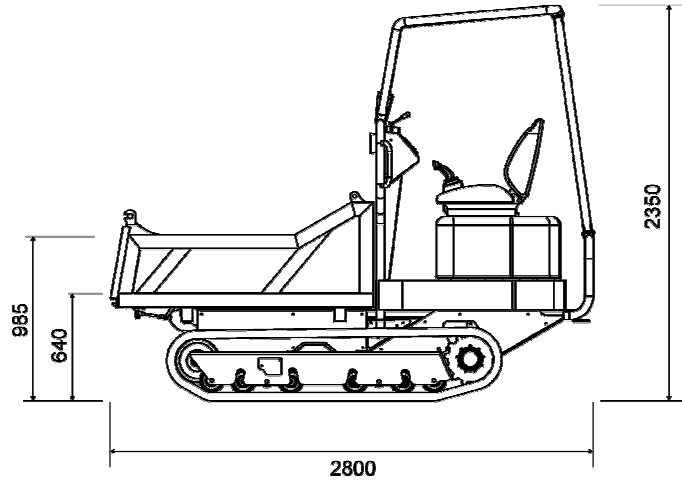
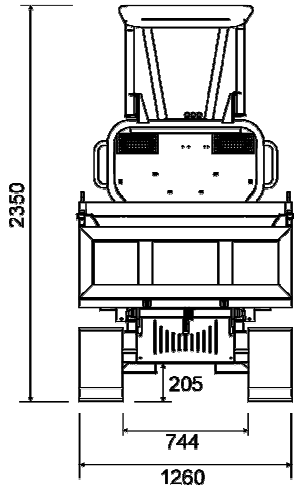

(misure in mm / measure are in mm)

